

Qm

the true path to natural sound

# User manual

# Prestige Three Gen 2

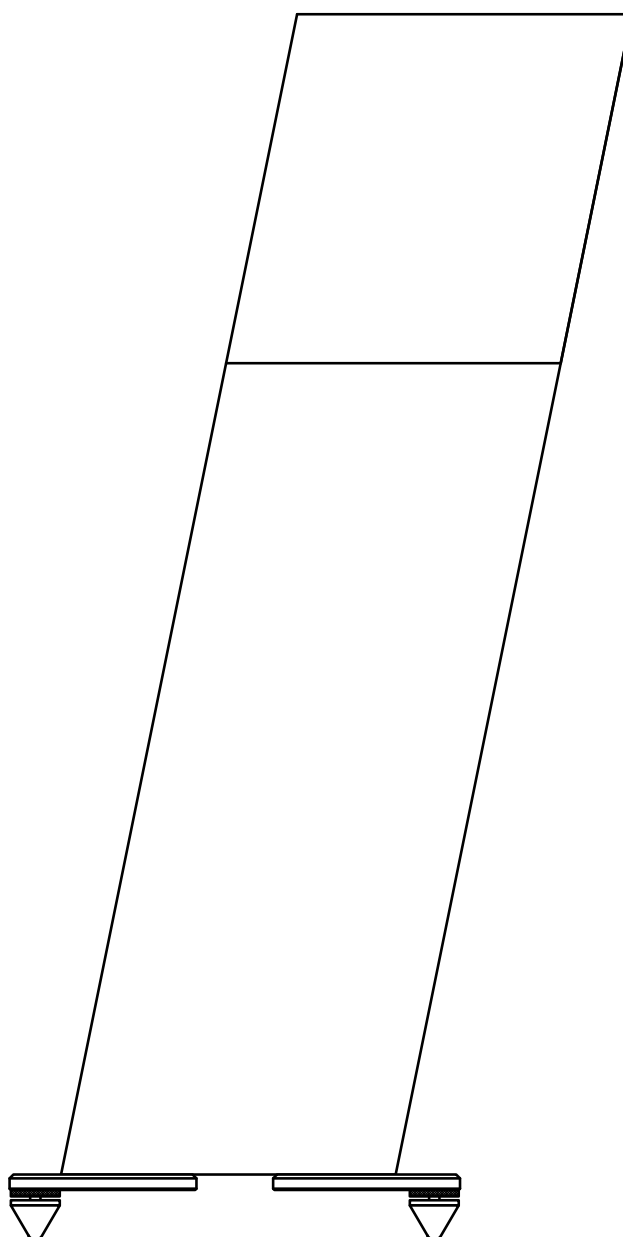

# User instructions for QIn loudspeakers

Thank you and congratulations for choosing the QIn Prestige Three Gen 2 loudspeaker. We at QIn hope you will get a lot of enjoyment from listening to music and that you will get very rewarding listening sessions for many years to come.

## **THE QIn Prestige Three Gen2**

The goal of the QIn Prestige Three Gen2 was to create a speaker with a combination of visual timeless design and the ability to make you just listen to music and not to the technical solutions involved.

Where others show off their technical solutions, we try to hide them and just present a piece of musical furniture that can be nicely placed in your living room. All the technical solutions are present, but the only role for them is to recreate the recorded music from your source. We must not forget, that the purpose of a speaker is to recall an original sound event, making it live again and providing the same emotions we feel when listening to a big orchestra, a string quartet, a rock band, a jazz trio or just a vocal with a piano.

This is why QIn look at speakers as musical instruments. We know that good sound depends on the acoustic chamber - just like in a string instrument. But opposite to music instruments we don't create sound, we just reproduce it.

QIn has always searched for cabinet shapes and proportions that will guarantee exceptional control of internal resonance, perfect acoustics, excellent driver stability, phase response and easy integration in rooms.

The unique QIn truncated pyramid cabinet design, launched in 1980, was the worlds first with this design for a bookshelf speaker. The asymmetry further launches the concept of no parallel walls and driver time alignment. These are the most important features that is built in Prestige Three together with Qboard® technology that gives no structural distortion. This means a dynamic, clean sound, rich in detail but totally natural.

As always, here at QIn the total functional design is the result of the demands for the resulting sound. Shape and function makes the QIn Prestige Three Gen 2 speaker!

## **Technology**

QIn Prestige Three Gen2 is designed using all the know-how we at QIn have acquired from producing highly prestigious speakers since 1979, combined with cutting edge measurements and long critical listening sessions. The speakers are assembled in Gothenburg Sweden, cabinets are made by skilled artisans with careful selection of the materials used and with strict checks carried out during the work in progress. This is a guarantee for speaker excellence and inalterability over time.

All the components are carefully selected, the drivers are made by Scan-Speak to our specifications, cross-over components and terminal post are from Germany and are made with great care using high quality components and maximum attention to the signal route.

### **1. Unpacking and maintenance**

Your speaker should be treated with the same care as you would treat a piece of furniture. Use a piece of soft cloth and a small quantity of warm soapy water to clean the loudspeaker. Avoid touching the cone of the bass unit or the treble dome since this may leave a mark or damage the dome and spoil its performance. After unpacking, we suggest you retain all packing material for future transports.

### **2. Break-in**

As with all high-quality loudspeaker systems, the musical performance of your QIn loudspeakers will improve over an initial break-in period. Please allow your new speakers to play a minimum 100 hours of music at normal listening levels before doing any critical listening. Up to 300-400 hours break-in will be needed for the speaker to reach it's fully potential of great sound.

### 3. Feet mounting

Feet mounting parts.

- 1pc M4 insex key
- 4pcs M8x35mm screws for puck and cone
- 4pcs M6x22mm screws for feet mounting
- 4pcs M6x30mm screws for feet mounting
- 4pcs M8 lock nut  $\varnothing=38\text{mm}$
- 4pcs Cone use to soft floor
- 4pcs Puck  $\varnothing=60$  use to hard floor

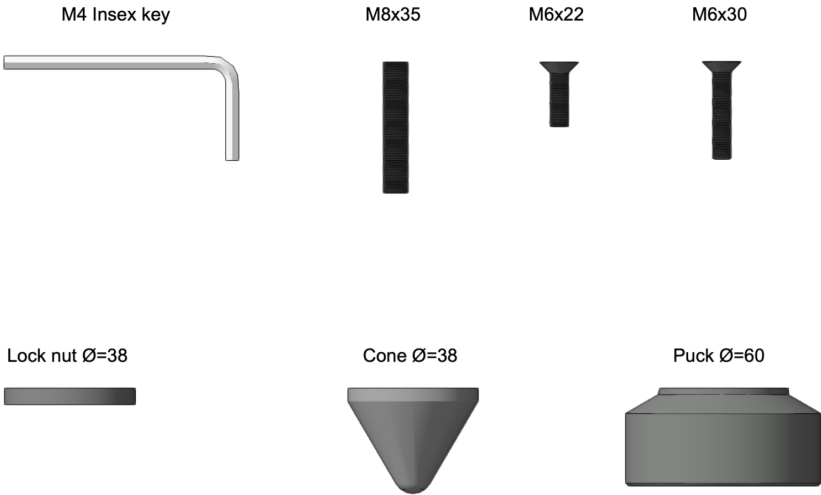

Be sure that the feet are mounted as figure below.

1. Long screws (30mm) at inner positions and short screws (22mm) at outer positions.

2. There are 4 mounting holes at the feet. For front feet use hole No. 2 & 4 from inside (the not rounded end). So the feet are at the inner position and feet at the back use hole 1 & 3 from inside. So the feet are at the outer positions for best safety balance.

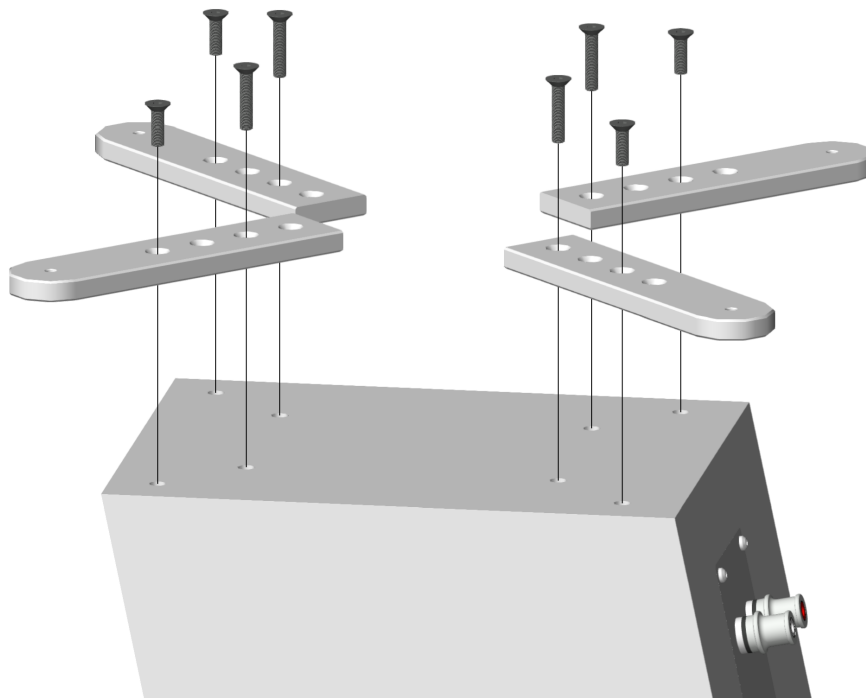

#### 4. Puck or Cone mounting

Mount M8x35mm screw to the feet, use M4 inset key mount it tight to the feet. Screw lock nut close to the feet. Then mount cone or puck depending on the floor. Cone for soft floor with carpet or rug, Puck to hard floor wood or stone(or similar).

To obtain proper mechanical coupling to the floor, adjust until all four cones or pucks have equal contact.

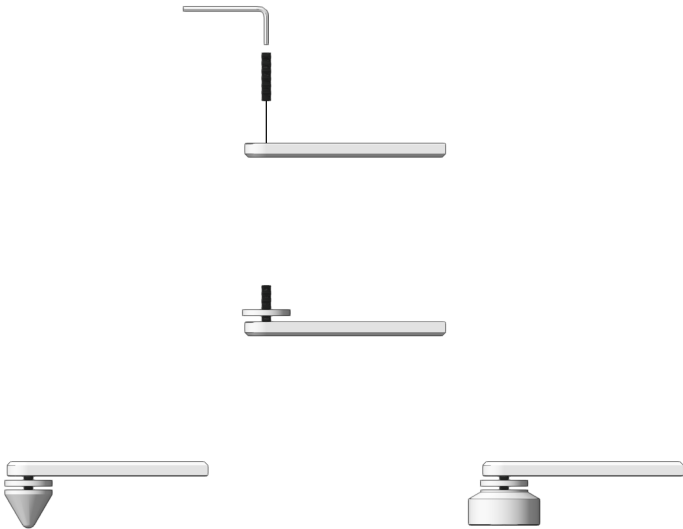

## 5. Room positioning

The performance of a loudspeaker system in a room varies with placement. Ideal positioning of the speakers is 3-4 m apart and preferably at least 0.5-1m away from side and rear walls. Avoid distances from walls that correspond to  $1/2$ ,  $1/4$ ,  $1/6$  etc., of the room dimensions. Seek instead odd fractions;  $1/3$ ,  $1/5$ ,  $1/7$  etc. to minimise effects of room related resonances.

The longer distance from the back wall, the deeper stereo image you will get. You can also place some damping or diffusing material on the back wall behind the speaker, which can help you to get a deeper stereo image.

It's important that the distance from the listener to each speaker is equal. Differences less than one cm can make difference. Use a small rope or laser meter to set the distance as equal as possible.

You will perceive the most accurate sound stage if you listen from a position halfway between the loudspeakers and three to four metres away.

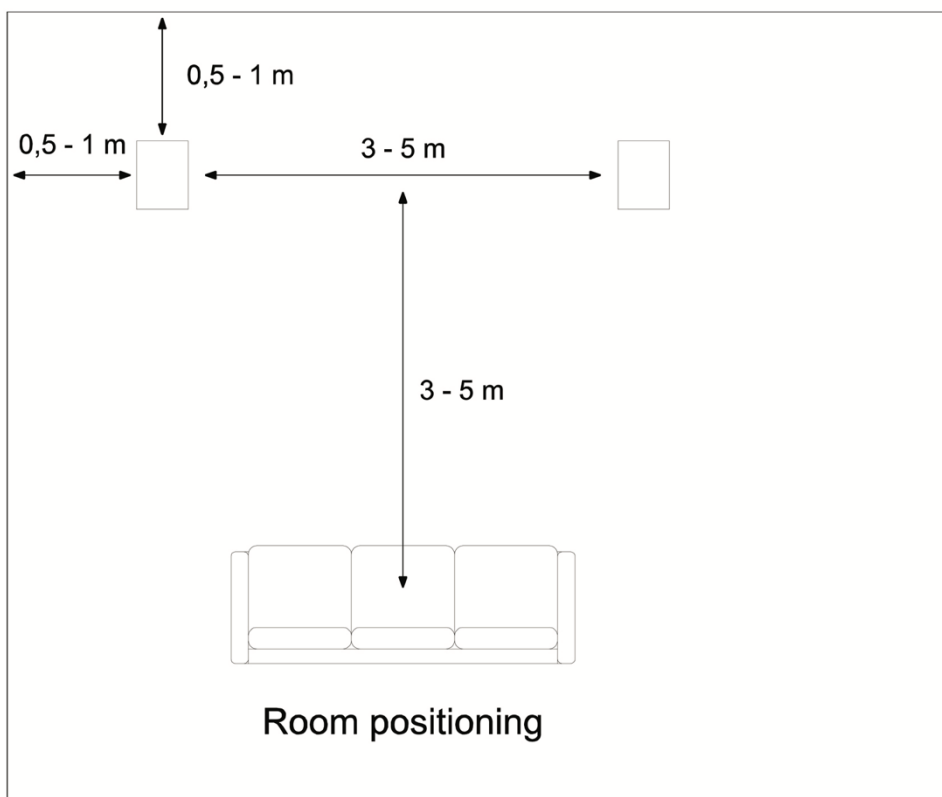

Avoid corner placement as it leads to colouration and often will over emphasise the lower frequencies. Image stability and stereo perception is increased if the two speakers are turned slightly towards the listening position. Start so you just can see around two cm of the inside wall of the speaker. Close to this is normally the best. More toe in will make the stereo image and centre voices more narrow. The other way the voices will be wider. Try to find a position where you get a wide and even stereo perspective from left to right. Then try for best stereo image and centre focus. Objects in the direct sound path can disturb the coherence of the sound picture. Try out different positions before deciding on a final arrangement. And for serious listening - remove the front grill. We recommend a listening room from 15-50m<sup>2</sup>, but the speaker can also perform excellent in even larger rooms. Happy listening!

## **6. Connections**

We recommend the use of heavy gauge loudspeaker cables of high quality. Make sure to turn off all amplifiers before connecting your new speaker to your Hi-Fi system.

Connect the cable to the terminal. Use the marking of the cable to ensure that the red or "+" mark of the amplifier is connected to the "+" side of the terminal, also marked with red. Often there also is a direction mark on the speaker cable. It can be an arrow or a text pointing in direction to the speaker.

## **7. Power handling**

I recommend using amplifiers within a specific power range, see under specifications. However, more important is that the amplifier has sufficient power reserves for handling of the peaks and transients in the music signal.

The power-rating figure of a loudspeaker is a very imprecise figure. Since the energy in the music signal varies, neither peak nor average value is relevant. A power rating of 100W RMS only says that you can play a continuous tone of 1kHz at this output. It doesn't mean that you can turn the volume all the way up on a 100W amplifier and expect a clear sound and healthy speakers.

The greatest danger to a loudspeaker is a distorted signal. Distortion in the low frequency range produces overtones in the entire spectrum, with an energy that can easily damage the tweeter units. And since a more

powerful amplifier can play louder without distortion, we have the paradox that it is a greater risk to damage speakers by playing loud with a smaller amplifier.

### **Caution!**

If you hear distortion when you increase the volume this is normally a sign of overloading the amplifier and you should immediately reduce the output level. Use of loudness, bass or treble boost increases the risk for harmful distortion in the amplifier. We recommend that you use such controls with care or bypass them if possible.

### **8. Service**

Should your QIn loudspeaker system require service, or if you have difficulty in achieving the fine performance, of which your QIn loudspeaker system is capable, consult the QIn dealer where the system was purchased. Your dealer has the knowledge required to provide expert advice and assistance. In case the QIn dealer is unable to assist you, you are welcome to contact us at QIn direct by email. [info@qin.se](mailto:info@qin.se). You also find contact info at our homepage, [www.qin.se](http://www.qin.se). Regrettably we cannot give direct telephone support to end-users.

### **9. Warranty**

This QIn loudspeaker is warranted to the original purchaser against factory defects in material or workmanship for a period of 5 years from the date of original purchase. This warranty is valid only in the country of purchase, to the original purchaser and is non-transferable.

QIn loudspeakers are music listening devices and should be used for listening purposes only. They must not be connected to any other equipment than amplifiers within the specified power range.

QIn cannot be held responsible for damage or injuries caused by improper use or use in violation with the recommendations in this leaflet.

**Specification**

Impedance: 8 ohms

Amplifier requirements: 25-250 Watt RMS

Sensitivity: 88 dB SPL 1 Watt/1m

Low frequency performance: -3dB 28Hz

Cabinet: Dual layer Qboard®

Terminal: Single wire, WBT Nextgen®

Dimensions (HxWxD): 900x210x420, with feet 954x310x483

Weight: 27 kg each

Finish: Walnut matt, Walnut dark piano,

[info@qln.se](mailto:info@qln.se) [www.qln.se](http://www.qln.se)

Gothenburg Sweden